

MS ENG. 20KG/CM² FLANGED STRAINER

MODEL NO : WST - 3121

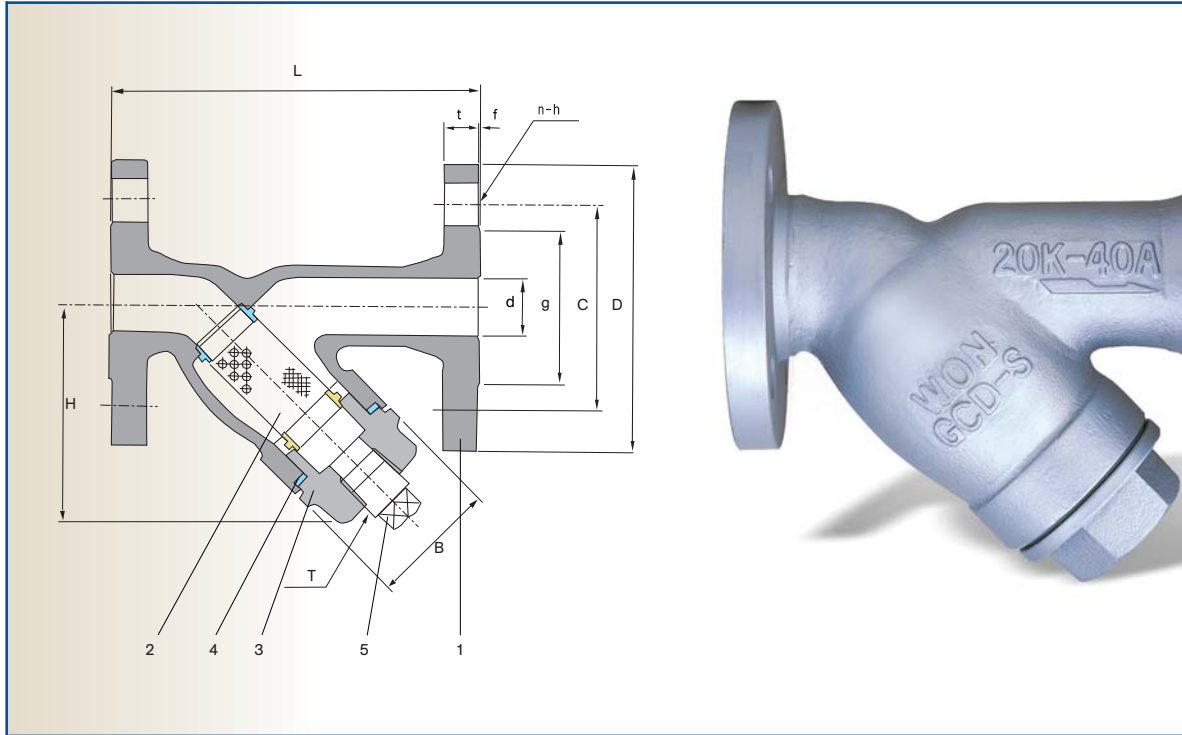

■ MATERIAL

NO.	PART NAME	MATERIAL
1	BODY	GCD-S
2	SCREEN	STS 304
3	CAP	GCD-S
4	PACKING	ASBESTOS
5	PLUG	SF45

■ SPECIFICATION

- Hydrostatic test pressure : 2.94MPa
- Pneumatic test pressure : 1.96MPa
- Screen size : 60 mesh
- Fluid : L.P.G, NG, NH₃, steam

■ DIMENSION

unit : mm

SIZE	H	L	B	d	g	C	D	t	f	n - øh	T
15A	80	130	48	15	51	70	95	13	1	4-15	-
20A	80	140	50	20	56	75	100	15	1	4-15	-
25A	95	160	56	25	67	90	125	15	1	4-19	-
40A	130	210	76	40	81	105	140	16	2	4-19	PT 1/2"
50A	150	250	96	50	96	120	155	16	2	8-19	PT 3/4"

※ Remark 1. Please contact us when applying for other gases

※참고 1. 다른 가스 용도로 사용할 경우 당사로 연락바람.